

Hose Station Proof Switch Assemblies

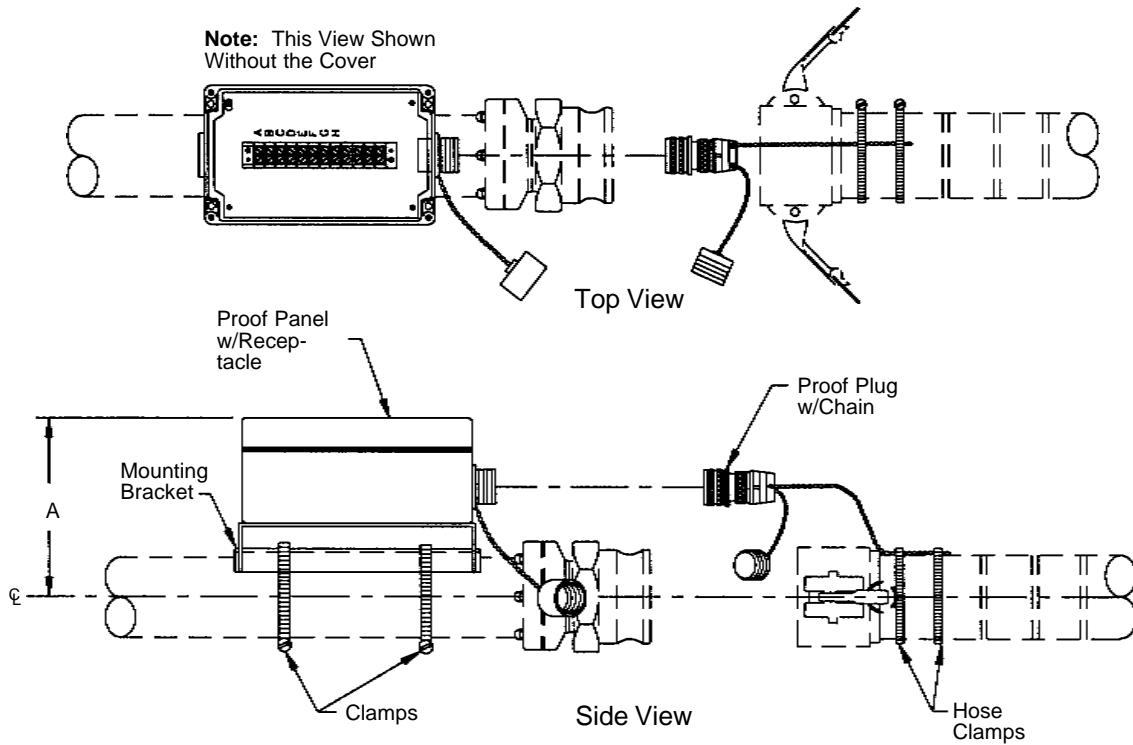

Proof Panel Assemblies

Conveying Line Size	Part Number	A
1 1/2"	F15710-1	5 1/16
2"	F25710-1	5 5/16
2 1/2"	F35710-1	5 7/16
3"	F45710-1	5 13/16
4"	F55710-1	6 5/16
5"	F65710-1	6 7/8
6"	F75710-1	7 3/8
8"	F85710-1	8 3/8

Includes (4) screws, lockwashers, and nuts to bolt panel to mounting bracket
 (2) clamps to mount bracket to conveying line
 (1) mounting bracket
 (1) panel with receptacle

Proof Plug Assemblies

Conveying Line Size	Part Number
1 1/2"	F15710-2
2"	F25710-2
2 1/2"	F35710-2
3"	F45710-2
4"	F55710-2
5"	F65710-2
6"	F75710-2
8"	F85710-2

Includes (1) proof plug with chain
 (2) hose clamps

